

# Mega Top Units

Food Prep Tables-Mega Top  
Super Deluxe Series

Exceptional Quality **2 Years Parts and Labor Warranty**



## FEATURES / BENEFITS

- EFFICIENT REFRIGERATION SYSTEM**  
 Turbo Air's solid door refrigerators are designed with oversized and balanced (CFC Free R-134A) refrigeration systems. These include efficient evaporators and condensers for faster cooling and greater efficiency.
- COLD AIR COMPARTMENT**  
 Our innovative "Cold Air Compartment" maintains temperature evenly for each pan to preserve fresh food longer. In addition, the compartment isolates pans from the reach-in area to prevent food spillage.
- STAINLESS STEEL CABINET CONSTRUCTION**  
 The Turbo Air Super Deluxe model boasts a stainless steel interior and exterior (except the back). It guarantees the utmost in cleanliness and long product life. The Super Deluxe can add a touch of style to the most refined setting.
- HIGH-DENSITY POLYURETHANE INSULATION**  
 The entire cabinet structure and solid doors are formed-in-place using high density, CFC free polyurethane insulation.
- MAGNETIC DOOR GASKETS**  
 Magnetic door gaskets are of one piece construction, removable without tools for ease of cleaning and replacement.
- STURDY, CLEAN STAINLESS SHELVING**  
 Shelves are the most important part of cleanliness as they come in direct contact with food. After a while, PVC coated wire shelves may peel, rust and lead to unsanitary conditions. Only the Turbo Air Super Deluxe series uniquely provides stainless shelving.
- ERGONOMICALLY DESIGNED DOORS**  
 Customers' fatigue fades away with easy grip handles and doors that open effortlessly. These features along with self-closing doors make this the ultimate choice in customer convenience. ABS sheet door liners resist water condensation with thermal efficiency.
- CONVENIENT CUTTING BOARD SIDE RAIL**  
 The new side rail cutting board bracket makes it easy to secure and remove the cutting board and it accepts different sizes too (max. 1/2" thickness)
- HOT GAS CONDENSATE SYSTEM**  
 Through Turbo Air's creative innovation, the condensate system surfaces have been specially treated to resist corrosion. This not only increases efficiency without the risk of refrigerant leakage from corrosion, but also prevents the overflow of condensate water.
- REFRIGERATOR HOLDS 33°F ~ 39°F FOR THE BEST IN FOOD PRESERVATION**

## \* Insulated Pan Cover

Model	Swing Door	CU./FT.	#of Shelves	#of Pans	#of Hood	HP	AMPS	Crated Weight	L D H
TST-28SD-12	1	8	1	12	1	1/3	66	220	27 1/2 x 34 x 39
TST-36SD-15	2	11	2	15	1	1/3	66	242	36 3/8 x 34 x 39
TST-48SD-18	2	15	2	18	1	1/3	65	264	48 1/4 x 34 x 39
TST-60SD-24	2	19	2	24	2	1/2	89	352	60 1/4 x 34 x 39
TST-72SD-30	3	23	3	30	2	1/2	99	396	72 5/8 x 34 x 39

\* Height does not include 6-1/2" for caster height.



# TST MODELS SPECIFICATIONS

MODEL	TST-28SD-12	TST-36SD-15	TST-48SD-18	TST-60SD-24	TST-72SD-30
Exterior Dimension(LxDxH)	27 1/2x34x39	36 3/8x34x39	48 1/4x34x39	60 1/4x34x39	72 5/8x34x39
Cubic Feet	8	11	15	19	23
Compressor (HP)	1/3	1/3	1/3	1/2	1/2
# of Shelves	1 ea	2 ea	2 ea	2 ea	3 ea
Net Weight	206 lbs	226 lbs	244 lbs	321 lbs	356 lbs
Voltage Ⓢ NEMA-5-15P	Ⓢ115/60/1	Ⓢ115/60/1	Ⓢ115/60/1	Ⓢ115/60/1	Ⓢ115/60/1
Amp	6.6 A	6.6 A	6.5 A	8.9 A	9.9 A
Cord Length (ft.)	9	9	9	9	9
Plug-In	NEMA 5-15P	NEMA 5-15P	NEMA 5-15P	NEMA 5-15p	NEMA 5-15P
#of Pans	12 ea	15 ea	18 ea	24ea	30ea

\*Design and specifications subject to change without notice.

- **SELF-CONTAINED SYSTEM**
- **2.5" CASTERS AVAILABLE FOR ALL MODELS (OPTIONAL)**
- **5" SWIVEL CASTERS**
- **LEGS AVAILABLE FOR ALL MODELS (OPTIONAL)**
- **STANDARD 1/6 SIZE, 4" DEEP CONDIMENT PANS INCLUDED**
- **REMOTE CABINETS AND CONDENSING UNITS AVAILABLE FOR ALL MODELS.**

- **WARRANTY : 2 Years Labor and Parts Warranty  
Additional 3 Years Warranty on Compressor**

(unit : inch)

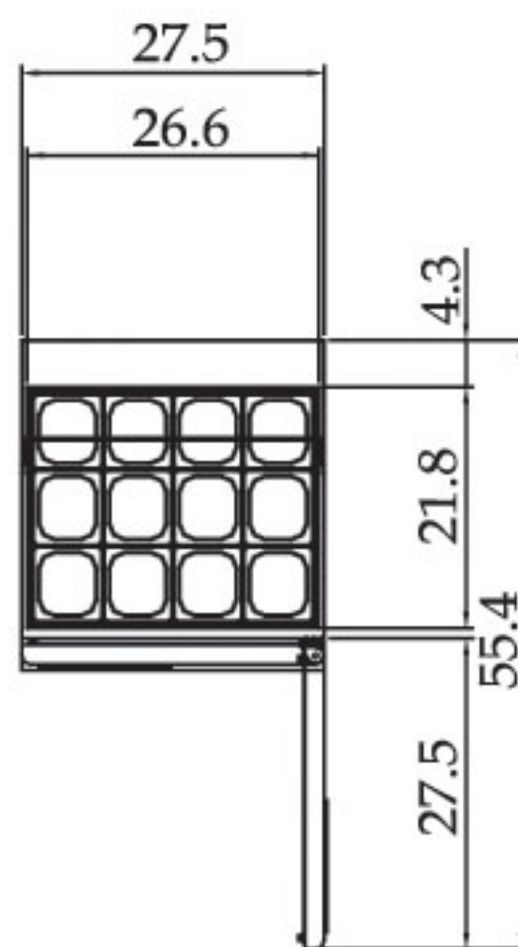

TST-28SD-12 PLAN VIEW

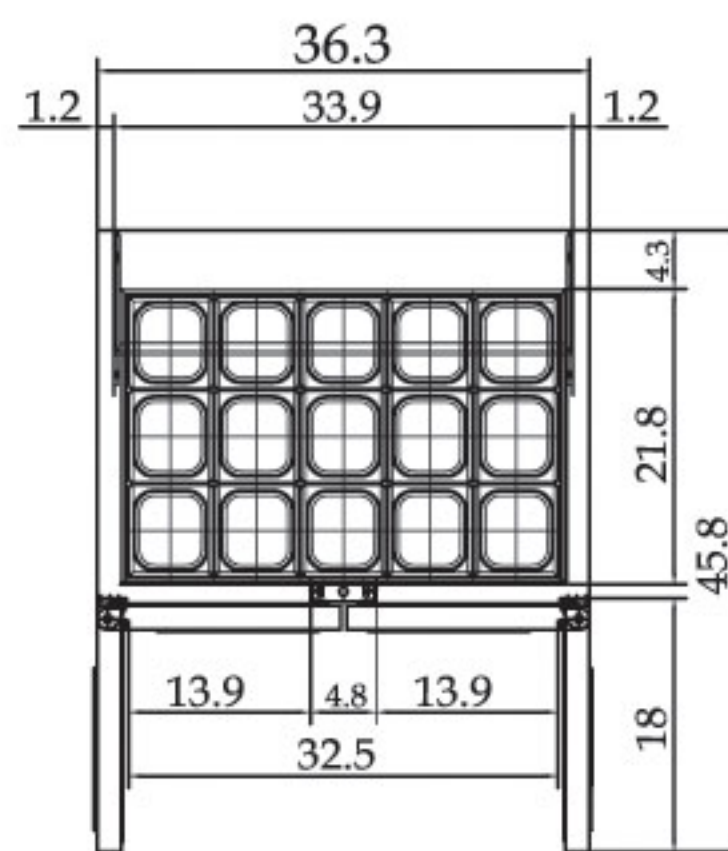

TST-36SD-15 PLAN VIEW

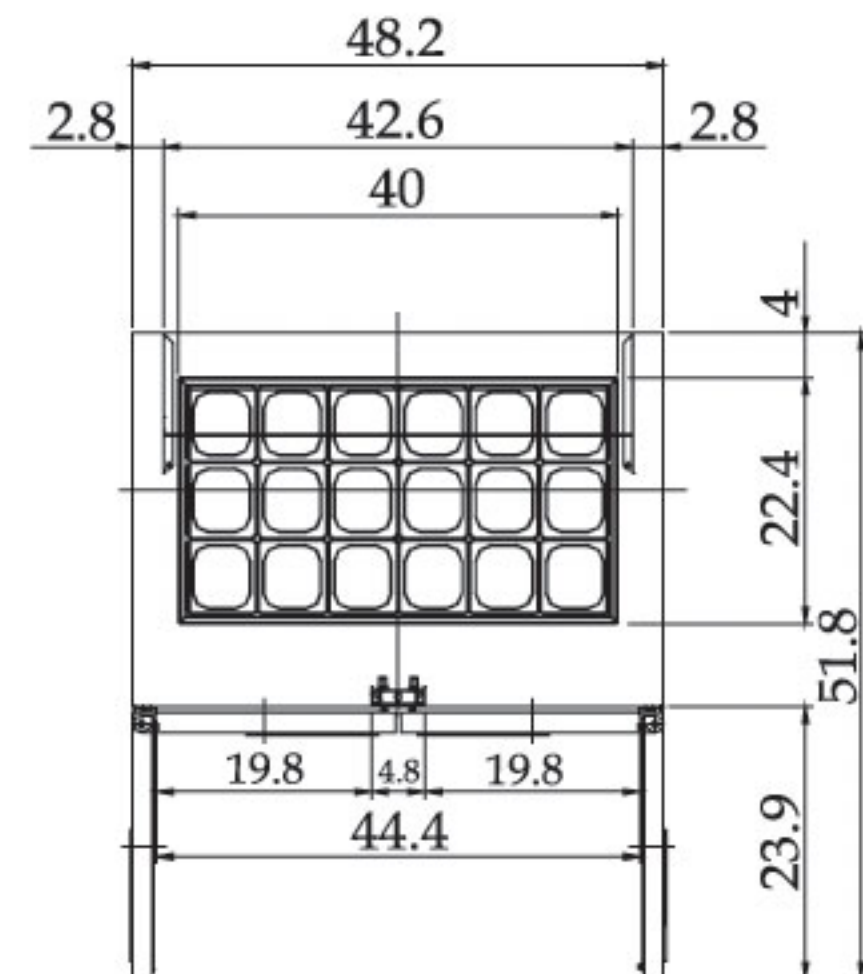

TST-48SD-18 PLAN VIEW

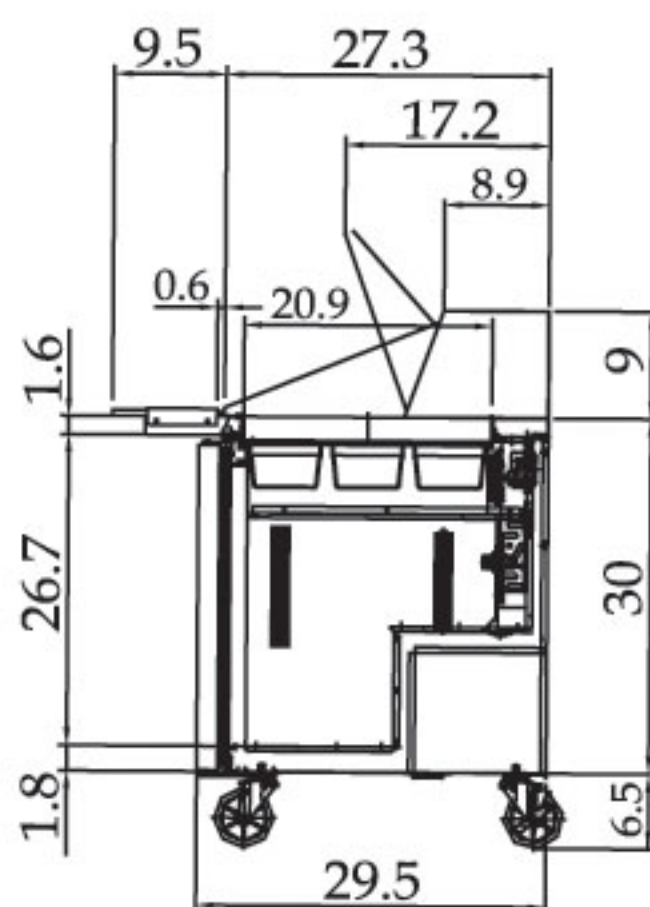

SIDE VIEW

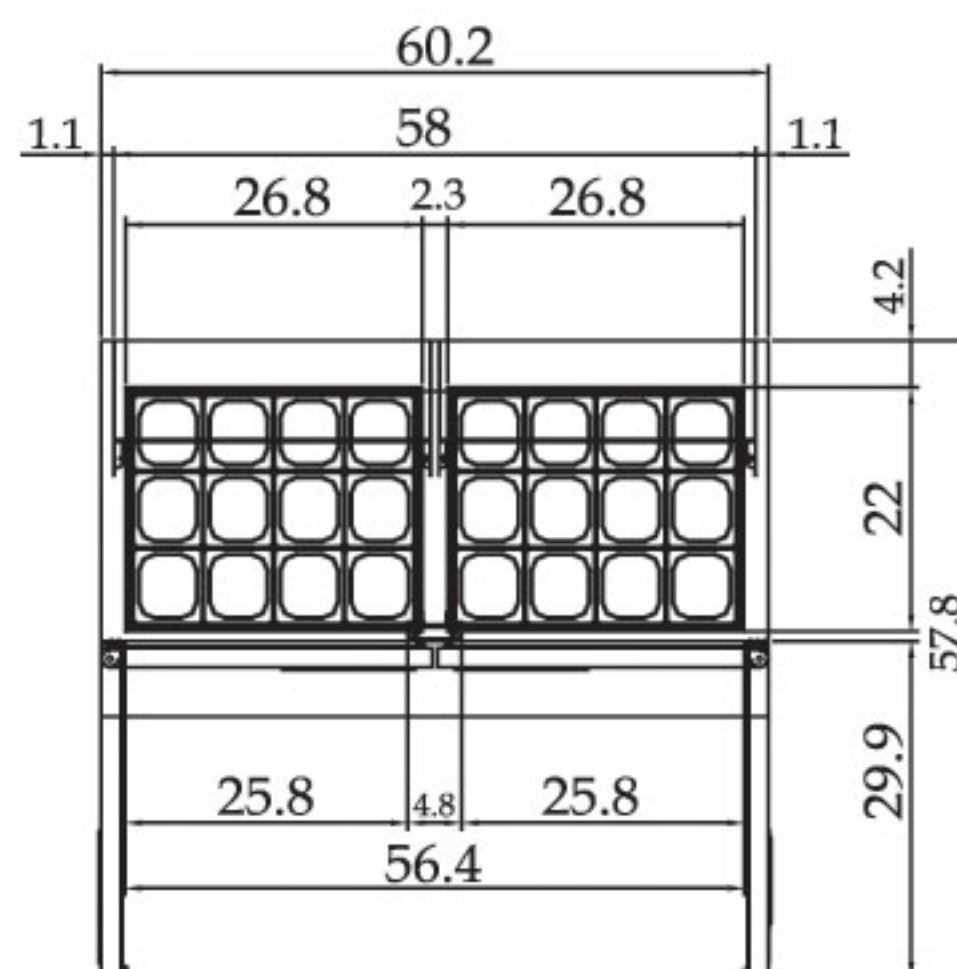

TST-60SD-24 PLAN VIEW

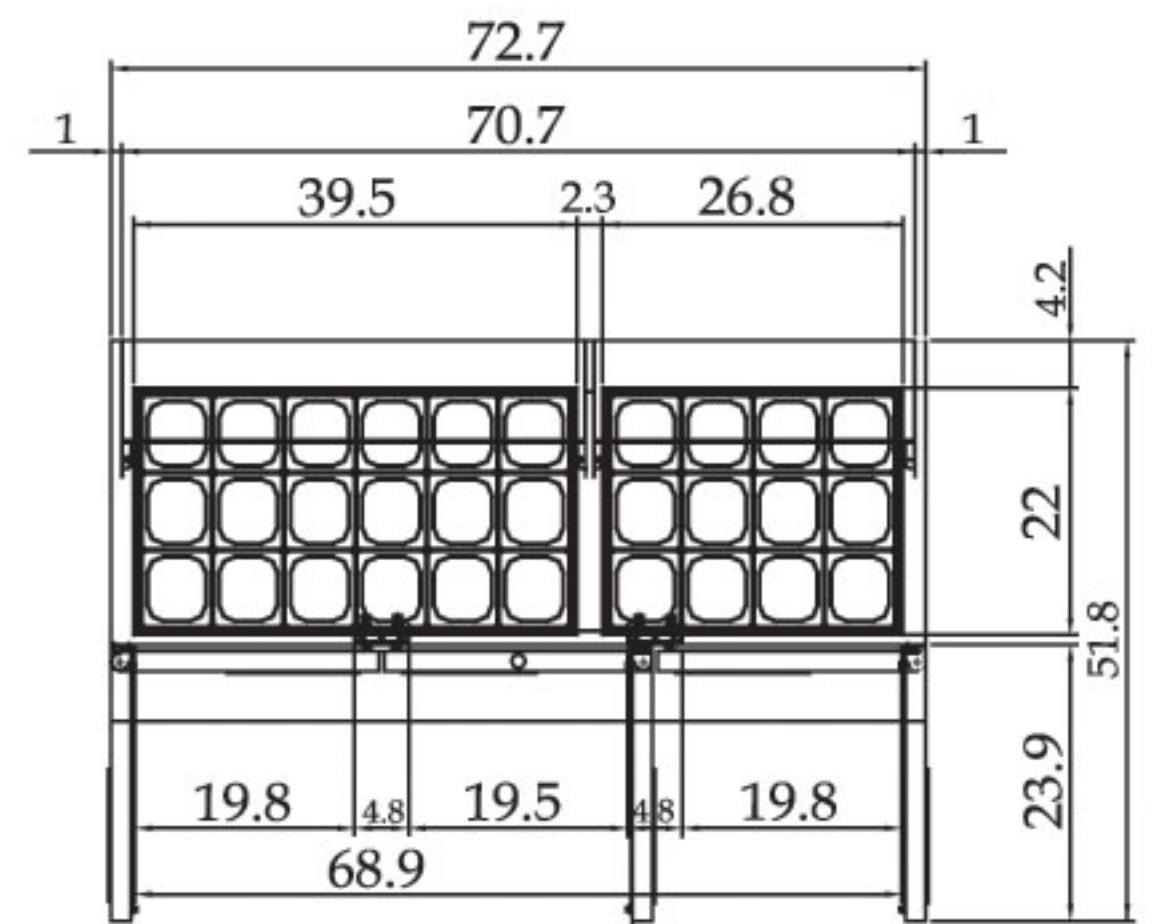

TST-72SD-30 PLAN VIEW