

Glass Door Merchandisers

Glass Door Merchandisers
Refrigerators

Swing Door Models



TGM-5R

TGM-11RV

TGM-14RV

TGM-22RV

FEATURES / BENEFITS

EFFICIENT REFRIGERATION SYSTEM

Turbo Air glass door refrigerators are designed with oversized and balanced (CFC Free R-134A) refrigeration systems. These include efficient evaporators and condensers for faster cooling and greater efficiency.

TASTEFUL AND MODERN APPEARANCE

The design of our products is one of our top priorities. Whether you have a restaurant, bar, convenience store or gas station, Turbo Air refrigerators will compliment the appearance of your operation.

DOUBLE PANE GLASS DOORS WITH HEAT REFLECTING FILM

Equipped with unique double pane glass doors with a layer of patented, transparent thermal insulating film applied between the two glass layers. Lightweight door construction reduces door maintenance and roller wear, and facilitates smooth door opening.

MAGNETIC DOOR GASKETS

Magnetic door gaskets are of one piece construction, removable without tools for ease of cleaning and replacement.

* Actual shelf organizer may differ in appearance with above picture.

ADJUSTABLE, HEAVY DUTY, PE (POLYETHYLENE) COATED WIRE SHELVES

HIGH-DENSITY POLYURETHANE INSULATION

The entire cabinet structure is formed-in-place using high density, CFC free polyurethane insulation.

ERGONOMICALLY DESIGNED DOORS

Customers' fatigue fades away with easy grip handles and doors that open effortlessly. These features along with self-closing doors make this the ultimate choice in customer convenience.

HOT GAS CONDENSATE SYSTEM

Through Turbo Air's creative innovation, the condensate system surfaces have been specially treated to resist corrosion. This not only increases efficiency without the risk of refrigerant leakage from corrosion, but thoroughly prevents the overflow of condensate water (except TGM-5R).

BOTTOM MOUNT COMPRESSOR UNITS

Turbo Air's bottom mount compressor allows easier access for service and extra storage space above. In addition, the lower area provides a cooler and less greasy operating environment which results in reduced compressor running time.

REFRIGERATOR HOLDS 33°F ~ 38°F FOR THE BEST IN BEVERAGE PRESERVATION

Model	Swing Door	CU./FT.	#of Shelves	HP	AMPS	Crated Weight	L D H
TGM-5R	1	5	3	1/10	22	82	187/8 x 235/8 x 333/4
TGM-11RV	1	11	4	1/4	54	163	235/8 x 243/4 x 633/4
TGM-14RV	1	14	4	1/4	63	187	235/8 x 261/8 x 735/8
TGM-22RV	1	22	4	1/4	7.6	243	283/4 x 301/4 x 797/8

MODEL	TGM-5R	TGM-11RV	TGM-14RV	TGM-22RV
Exterior Dimension(LxDxH)	187/8x235/8x333/4	235/8x243/4x633/4	235/8x261/8x735/8	283/4x301/4x797/8
Interior Dimension(LxDxH)	161/4x17x291/4	187/8x193/4x443/4	19x197/8x571/2	241/8x235/8x621/8
Compressor (HP)	1/10	1/4	1/4	1/4
Voltage (NEMA-5-15P)	115/60/1	115/60/1	115/60/1	115/60/1
Amp	2.2 A	5.4 A	6.3 A	7.6 A
Cord Length (ft.)	9	7	7	6
Plug-In	NEMA 5-15P	NEMA 5-15P	NEMA 5-15P	NEMA 5-15P
Net Weight	75 lbs	137 lbs	168 lbs	225 lbs
# of Shelves	3 ea	4 ea	4 ea	4 ea
Shelf Size	A:161/8x141/4 B:161/8x153/4 C:161/8x9	201/4x141/2	A:203/8x167/8 B:191/2x167/8	251/2x193/8
Bottle Capacity	Full Load Line	114	150 120	280

- **WHITE COLOR CABINET & BLACK COLOR FRAME ON DOOR**
- **DOUBLE PANE GLASS DOOR WITH THERMAL FILM**
- **2" PLATE MOUNT CASTERS (OPTIONAL)**
- **GRAVITY SHELVES - FITS UP TO 20 OZ. BOTTLE (OPTIONAL)**
- **CUSTOMIZED GRAPHICS & COLORS AVAILABLE IN QUANTITY**

*Design and specifications subject to change without notice.

- **WARRANTY : 1 Year Labor and Parts Warranty
Additional 4 Years Warranty on Compressor**

(unit : inch)

TGM-5R PLAN VIEW

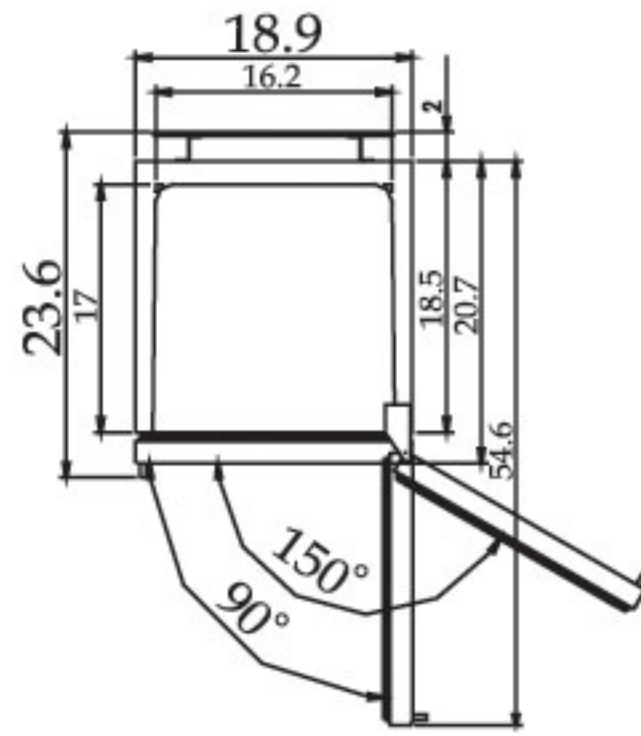

(unit : inch)

TGM-11RV PLAN VIEW

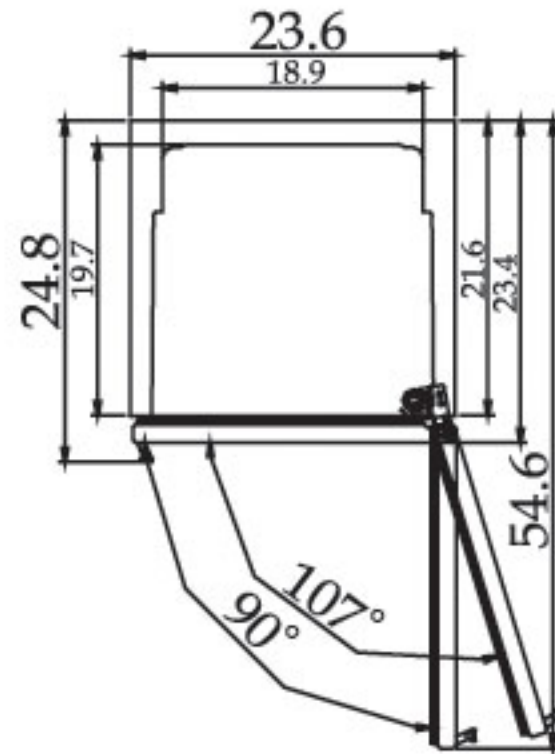

TGM-14RV PLAN VIEW

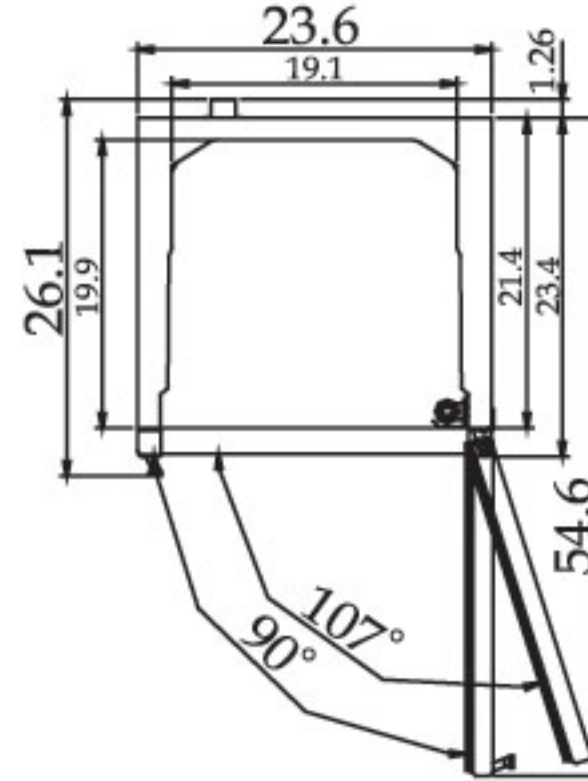

TGM-22RV PLAN VIEW

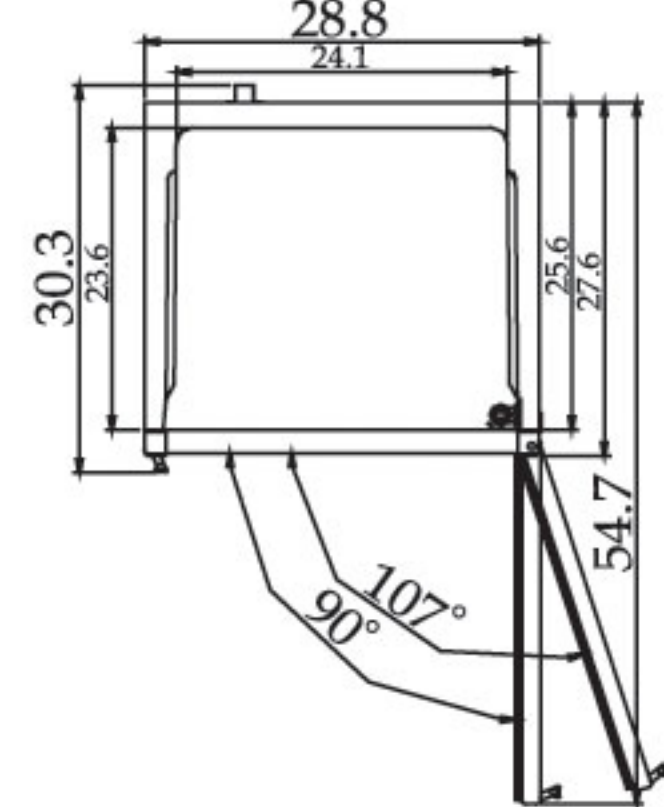

TGM-5R SIDE VIEW

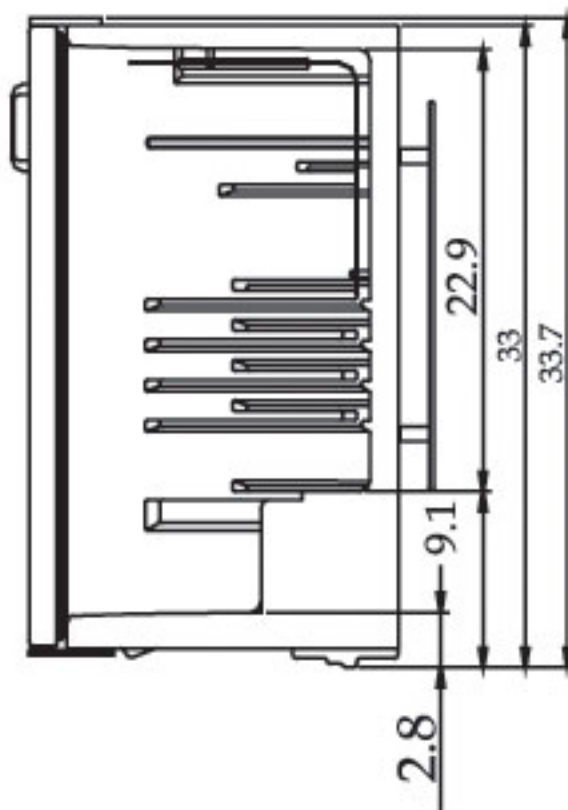

TGM-11RV SIDE VIEW

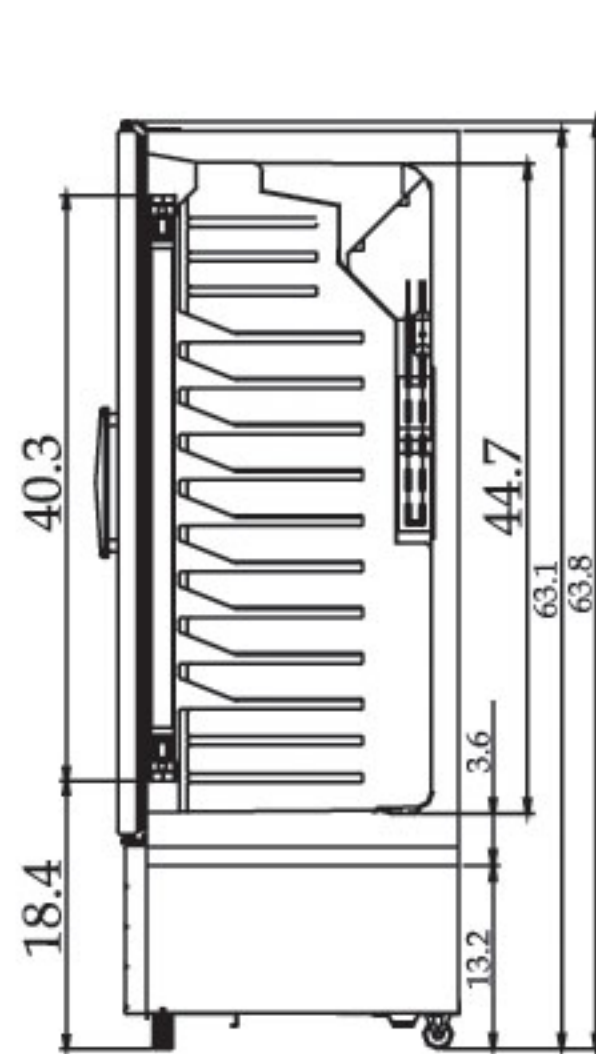

TGM-14RV SIDE VIEW

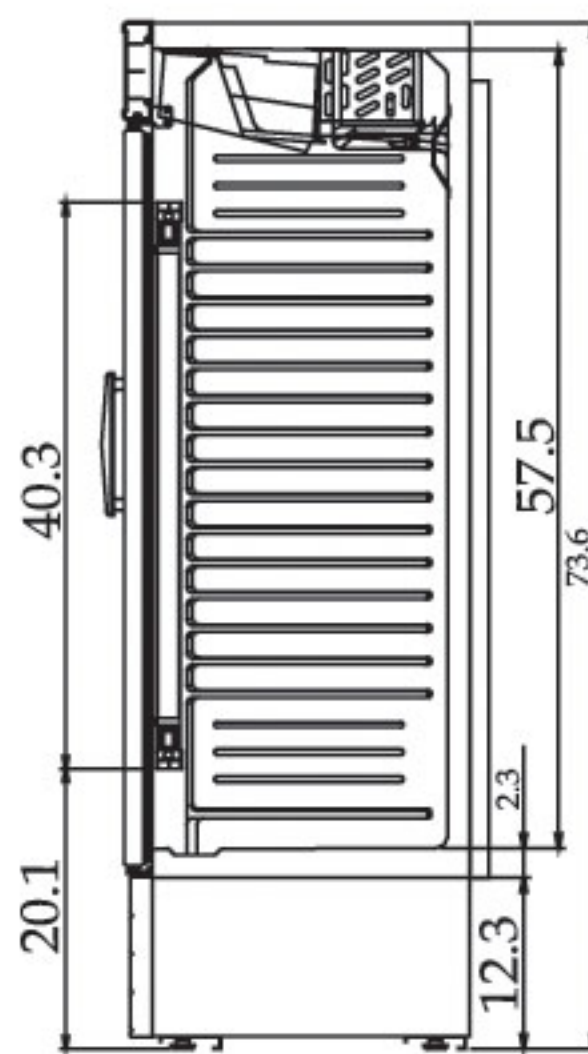

TGM-22RV SIDE VIEW

