

Glass Door Merchandisers

Swing Door Models



TGM-50RS



TGM-72RS

≡ FEATURES / BENEFITS ≡

- **EFFICIENT REFRIGERATION SYSTEM**
Turbo Air glass door refrigerators are designed with over-sized and balanced (CFC Free R-134A) refrigeration systems. These include efficient evaporators and condensers for faster cooling and greater efficiency.
- **TASTEFUL AND MODERN APPEARANCE**
The design of our products is one of our top priorities. Whether you have a restaurant, bar, convenience store or gas station, Turbo Air refrigerators will compliment the appearance of your operation.
- **DOUBLE PANE GLASS DOORS WITH HEAT REFLECTING FILM**
Equipped with unique double pane glass doors with a layer of patented, transparent thermal insulating film applied between the two glass layers. Light weight door construction reduces door maintenance and roller wear, and facilitates smooth door.
- **MAGNETIC DOOR GASKET**
Magnetic door gaskets are of one piece construction, removable without tools for ease of cleaning and replacement.
- **ADJUSTABLE, HEAVY DUTY, PE(POLYETHYLENE) COATED WIRE SHELVES**
- **HIGH-DENSITY POLYURETHANE INSULATION**
The entire cabinet structure is formed-in-place using high density, CFC free polyurethane insulation.
- **ERGONOMICALLY DESIGNED DOOR**
Customers' fatigue fades away with easy grip handles and doors that open effortlessly. These features along with self-closing doors make this the ultimate choice in customer convenience.
- **BOTTOM MOUNT COMPRESSOR UNITS**
Turbo Air's bottom mount compressor allows easier access for service and extra storage space above. In addition, the lower area provides a cooler and less greasy operating environment which results in reduced compressor running time.
- **REFRIGERATOR HOLDS 33°F ~ 38°F FOR THE BEST IN BEVERAGE PRESERVATION**

Model	Swing Door	CU./FT.	#of Shelves	HP	AMPS	Crated Weight	L D H
TGM-50RS	2	50	8	1/2	109	507	56 x 32 x 79
TGM-72RS	3	72	12	3/4	120	706	78 x 32 x 79

TGM-50RS / TGM-72RS SPECIFICATIONS

MODEL	TGM-50RS	TGM-72RS
Exterior Dimension(LxDxH)	56x32x79	78x32x79
Interior Dimension(in)	52 ⁸ / ₉ x23 ³ / ₅ x61 ² / ₇	74 ² / ₅ x20 ¹ / ₉ x61 ³ / ₅
Compressor (HP)	1/2	3/4
Voltage (i) NEMA-5-15P	Ⓢ115V/60Hz	Ⓢ115V/60Hz
Amp	10.9 A	12A
Power Cord Length	6.6 ft.	6.6 ft.
Plug-In Installation	NEMA 5-15P	NEMA 5-15P
Net Weight	463lbs	654lbs
Shelves	8EA	12EA
Shelf size	25 ¹ / ₅ x23 ² / ₅	23 ¹ / ₂ x23 ² / ₃
Bottle Capacity	Full	840
	Load Line	448

*Design and specifications subject to change without notice.

STANDARD FEATURES

- White color cabinet.
- White color frame on door.
- Double pane glass door with thermal film.
- Fully adjustable wire shelves with non-corrosive coating.

OPTION

- Casters (4" or 5") are available.
- Shelf dividers are available.
- Customized graphics & colors available in quantity



LISTED
COMMERCIAL
REFRIGERATOR
AND/OR FREEZER
438K



- **WARRANTY :** 1 Years Labor and Parts Warranty
Additional 4 Years Warranty on Compressor

(unit : inch)

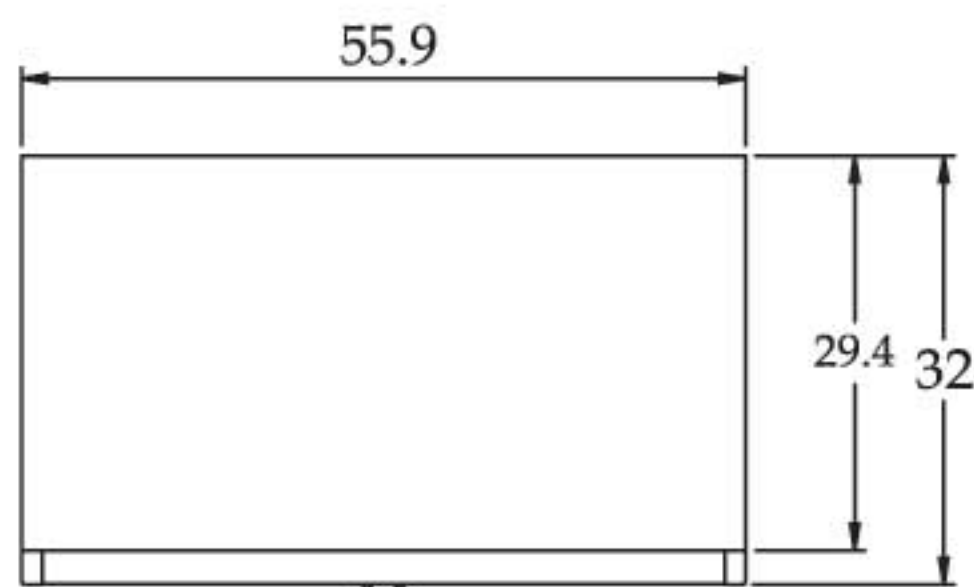

TGM-50RS PLAN VIEW

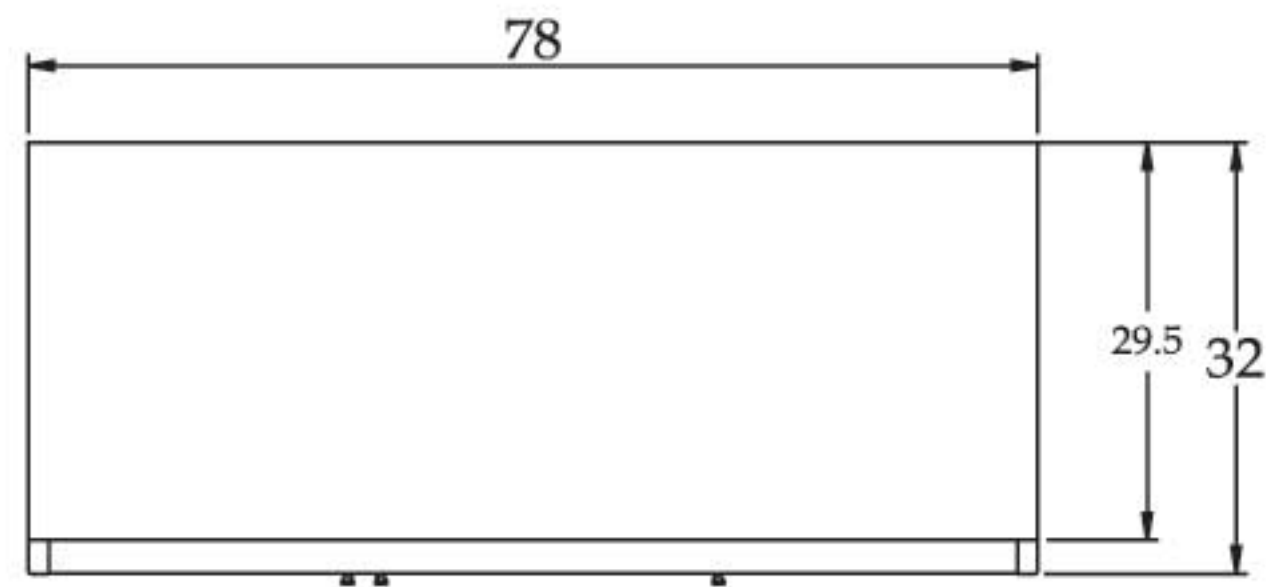

TGM-72RS PLAN VIEW

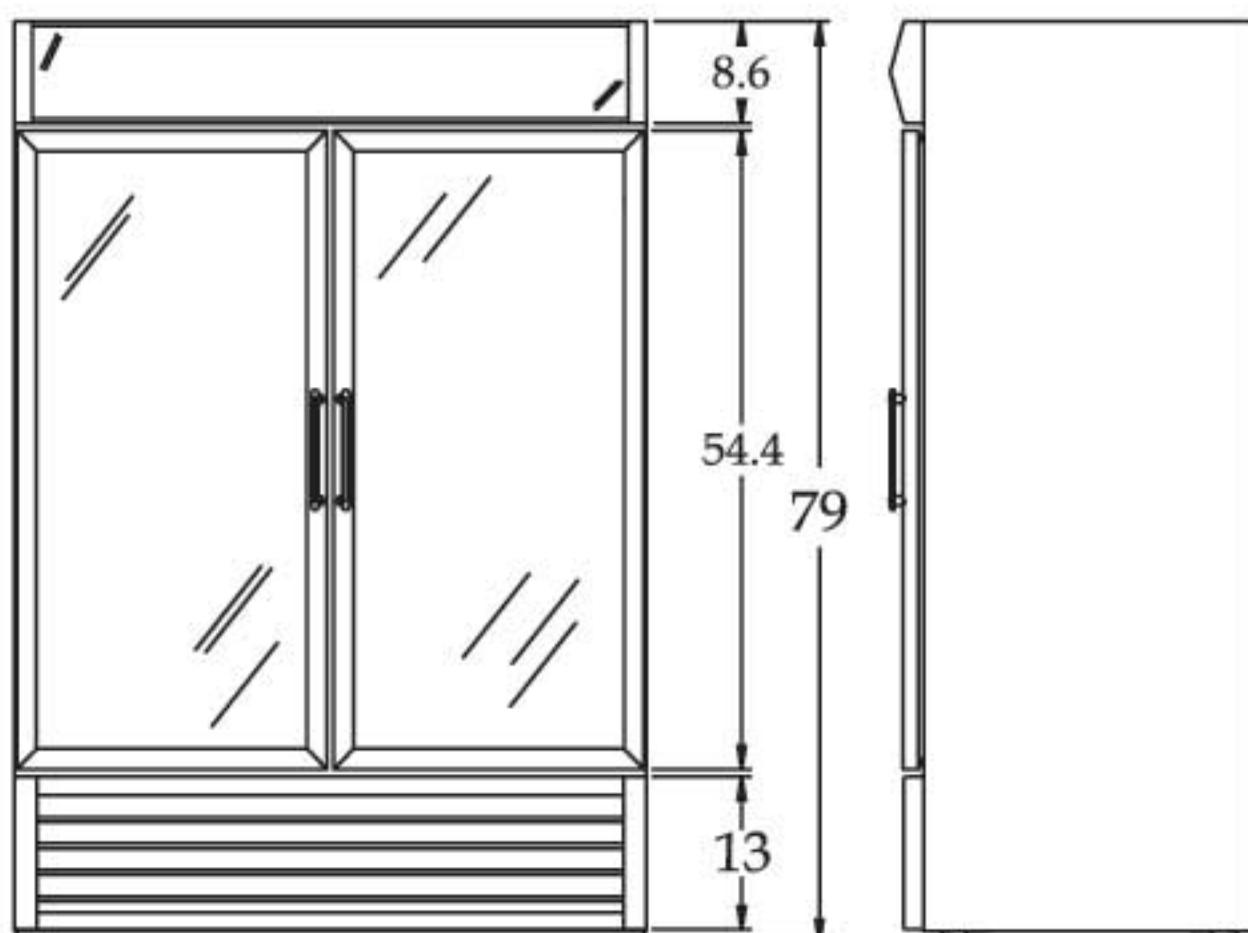

TGM-50RS FRONT VIEW

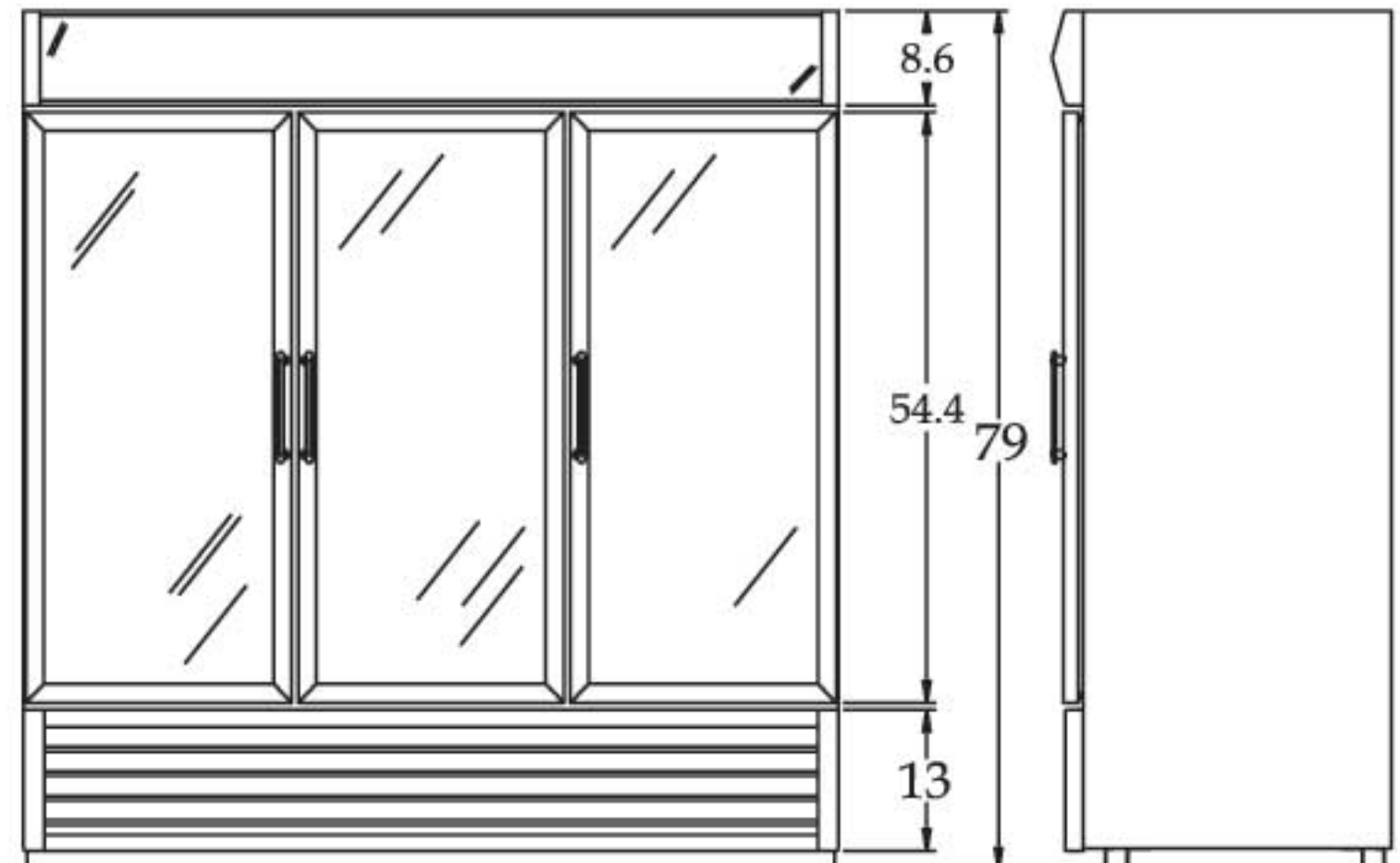

TGM-72RS FRONT VIEW